

R M

This unit is a pump which will clean the waste from a shower, washbasin or bath. It starts automatically.
SANIVITE and **SANISPEED**® can also pump away the waste from a washing machine, glass washer, and a sink.

LL O

The unit should be accessible for possible maintenance. The unit has fixing lugs that will stop any movement.

a CONNECTION SIDE INTLETS

Use connector ■ for connection of pipes to the side intlets. Secure with the plastic herbie clips. Cap off unused inlets with the end caps provided, after greasing the joints.
(SANIVITE® and **SANISPEED**®)

b CONNECTION TO LID INTLETS
(SANIVITE® and **SANISPEED**®)

To connect to a lid inlet, cut off the sealed cap with a hack saw and connect using the rubber connectors provided. Tighter with the plastic herbie clips.

c CONNECTION OF BATHROOM APPLIANCES
(SANIVITE® and **SANISPEED**®)

To connect a shower, ensure that the trap exit is 15 cm above floor level. Although not abligatory, a lid connection may be used to run an external air vent.

c CONNECTION OF BATHROOM APPLIANCES
(SANISHOWER®)

To install a shower next to the unit, connect one end of the connector to the inlet spigot, and the other end to the 40m shower waste. Secure using the herbie clips provided, tightening them with a pair of pliers/pincers.

Warning : Ensure that the shower trap exit is 60mm above ground level.

Installation under the tray : Lift the tray at least 145mm to accomodate the unit.

Warning : Prepare an access trap to the unit of at least L-400mm and H- 145mm (the access trap should be built so that tool is required to open it).

d DISCHARGE CONNECTION
(SANIVITE® and **SANISPEED**®)

The discharge should be in 32mm pipe, in copper or plastic (PVC, ABS....).

Observe the pumping parameters of the unit (vertical and horizontal combination).

All horizontal pipes should have a 1% (1cm per metre) fall on the horizontal pipe, all the way to the drain.

d DISCHARGE CONNECTION
(SANISHOWER®)

- Push the elbow ■ into the rubber discharge pipe and secure with clip ■.
- Connect the non-return valve ■ to the other end of the elbow and secure with clip ■.
- If the non-return valve is to be mounted horizontally, use some rigid 22mm pipe to join the discharge point to the non-return valve. Secure both ends with the clips ■.
- If the non-return valve is installed horizontally, the arrow should show along the top.

Connection to the optional inlet

- Use a cutter (e.g. Stanley knife) to remove the cap from the optional inlet (see figure 7d). Make sure the hole is not cut at an angle, and that the edges are deburred.

Warning : Make sure that this operation is carried out precisely, otherwise the joint will not be watertight.

- The rubber connector ■ can be used for 40 mm or 32 mm waste pipe. If fitting 32 mm waste, cut off the end of connector ■ (see figure 7d). Push the neck of connecto■ into the hole. If is a grip fit, which is why the hole must be cut accurately. Secure the waste pipe to ■ with clip ■.

TECHNICAL ADVICE FOR DISCHARGE
(SANIVITE® and **SANISPEED**®)

Orient the opening end of the non-return valve in the direction of the discharge. Secure with the large jubilee clip.

e IN CASE OF SERVICING

For possible service requirements, provide a drain off at the low point of the installation.

f CONNECT TO THE POWER SUPPLY

Connect to the power supply in accordance with electrical regulations BS EN 60335-1.

The connection should be to an unswitched fused connector with a 5 amp fuse.

Any service work sould only be carried out by a qualified person (eg Saniflo service engineer).

SANIVITE® and **SANISPEED**® : the units should be installed so they are easily accessible /removable for possible maintenance. The unit should not be exposed to splashing in normal use.

SANISHOWER® : Connect the wires in accordance with their colour coding :

live	=	brown
neutral	=	blue
earth	=	yellow/green

R

- The unit conforms with EN 12050-2 effluent lifting station.

9 R U

SANIVITE® and **SANISPEED**® are designed to handle the waste evacuation from a domestic kitchen sink, dishwasher and washing machine - all working at the same time if required. Its powerful pump will deal with every day normal usage.

SANISHOWER® is designed to handle a WC from a shower and handbasin.

Warning : Do not dispose of solvents, paints (do not wash paint brushes in sink), caustic, acid or other chemicals into these products.

Depending on usage, the **SANIVITE**® and **SANISPEED**® may need to be cleaned from time to time. Heavy usage can result in a build up of fat and grease.

The **SANIVITE**® and **SANISPEED**® unit will pump away water as hot as 60°C for a short period (i.e. to clear the hottest waste water from a washing machine). However, do not pour boiling water directly into the **SANIVITE**® and **SANISPEED**® unit.

When the **SANIVITE**® and **SANISPEED**® is pumping very hot water for a prolonged period of time, it will automatically cut out to protect the motor (thermal cut-out). When this happens the **SANIVITE**® and **SANISPEED**® will shut down long enough to cool down (approx.1 hour) and automatically resume normal operation when ready.

O M L

Disconnect from the power supply before attempting any work on the unit.

The unit does not require any specific maintenance.

In case of a service requirement, please call own Saniflo service engineer, especially for any electrical work.

U R

This unit is guaranteed for 2 years subject to correct installation and usage.

R**SOCIETE FRANÇAISE
D'ASSAINISSEMENT**

8, rue d'Aboukir
75002 Paris
 Tél. 01 44 82 39 00
 Fax 01 44 82 39 01

U**OM**

SANIFLO Ltd.,
 Howard House, The
 Runway
South Ruislip (Middx.,)
 HA4 6 SE
 Tel. (0208) 842 0033
 Fax (0208) 842 1671
 Telex: 934 335 G SANFLO

Ñ

GRUPO SFA
 C/ Cuzco, 41
08030 Barcelona
 Tel. (93) 381 85 97
 Fax (93) 462 18 96

U L

SFA SANIBROY GmbH
 Waldstr. 23 **Geb. B5**
63128 Dietzenbach
 Tel. (060 74) 30928-0
 Fax (060 74) 30928-90

Ö RR

SFA SANIBROY GmbH
 Am Heumark 7/14
1030 Wien
 Tel. 01 / 7 10 60 70
 Fax 01 / 7 10 60 70

RL

SFA BENELUX
 Voltaweg 4
6101 XK Echt
 Tel. (0475) 487 100
 Fax (0475) 486 515

SFA-SANIFLO INC.
 1-685 Speedvale
 Avenue West
Guelph ON - N1K 1E6
 Tel. +1 519 824 1134
 Fax +1 519 824 1143

R

SANIFLO AB
 BOX 86
S-133 22 Saltsjöbaden
 Tel. 08-717 5680
 Fax 08-717 8686

L

SFA SANITRIT spa
 Via del Benessere
27010 Siziano (PV)
 Tel. 03 82 61 81
 Fax 03 82 61 8200

РОССИЯ

SFA РОССИЯ
 101000 М В
 . Э 3 В , .
 28, .103
 Te . 963 19 40
 ф 963 19 40

R L

SANIFLO Ltd
 IDA Industrial Estate
Edenderry
County Offaly
 Tel. + 35 3469733102
 Fax + 35 3469733093

SERVICE HELPLINES**TEL****FAX**

France	N°Azur 0 810 05 90 02 <small>1 UT par appel</small>	03 44 94 46 19
United Kingdom	(08457) 650011 <i>(CALL FROM A LANDLINE)</i>	(0208) 8421671
Canada	+1 800 363 5874	+1 519 824 1143
Deutschland	0800 82 27 82 0	(060 74) 30928-90
Österreich	(01) 214 02 160	(01) 214 02 16 85
España	(93) 381 85 97	(93) 462 18 96
Nederland/België	(0) 475 487100	(0) 475 486 515
Belgique	32 (0) 67 44 29 59	32 (0) 67 44 44 75
Italia	(02) 988 0988	(02) 988 0335
Sverige	08-744 15 18	08-717 8686
P	(095) 963 19 40	(095) 963 19 40
Ireland	+ 35 3469733102	+ 35 3469733093

7

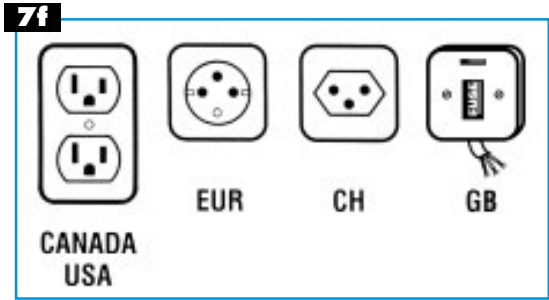
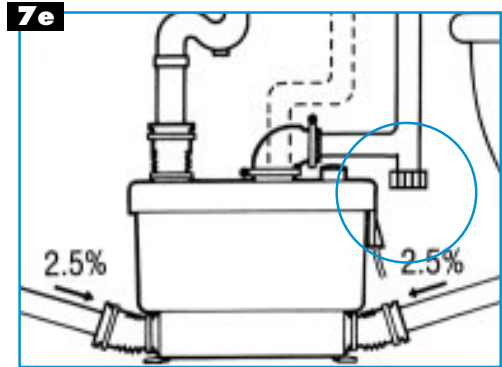
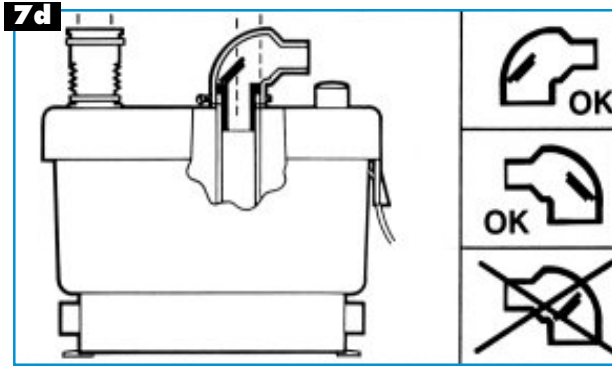

8

SANIVITE®
 Société Française d'Assainissement
EN 12050-2

FF02-V30
 220-240 V - 50 Hz - 350 W - IP44 - 1,7A - ⚡
 7,2 KG

